

## 4.8V to 30V Input, 1.5A LED Driver with Dimming Control

### FEATURES

- Up to 92% Efficiency
- Wide 4.8V to 30V Input Voltage Range
- 100mV Low Feedback Voltage
- 1.5A High Output Capacity
- PWM Dimming
- 10kHz Maximum Dimming Frequency
- Thermal Shutdown
- SOT23-6 Package

### APPLICATIONS

- High Brightness LED Driver
- Architecture Detail Lighting
- Constant Current Source
- Hand-held Lighting
- Automotive RCL, DRL, and Fog Lights
- Indicators and Emergency Lighting
- MR16 and other LED Bulb

### GENERAL DESCRIPTION

The ACT111A is a high efficient LED driver employing current-mode buck converter topology that supplies up to 1.5A from wide input voltage range from 4.8V up to 30V. The ACT111A is designed to operate as a constant source with 1.4MHz fixed frequency. ACT111A consists of a PWM control circuit, a high precision band-gap voltage reference, an oscillator, an error amplifier with internal compensation network and the N channel power MOSFET. An external sense resistor in series with the LED monitors output current allowing accurate current regulation, ideal for driving high current LEDs. The built-in fault condition protection circuits including current limiting, UVLO and thermal shutdown prevent itself from potentially faulty operation and burn-out.

The ACT111A is ideal for single 1W to 5W LED drivers. With its ultra low feedback voltage, a low current ripple, high efficiency of up to 92% step-down power LED driver can be easily composed of with additional several external components such as an inductor, a Schottky diode, a few resistors and capacitors.

### TYPICAL APPLICATION CIRCUIT

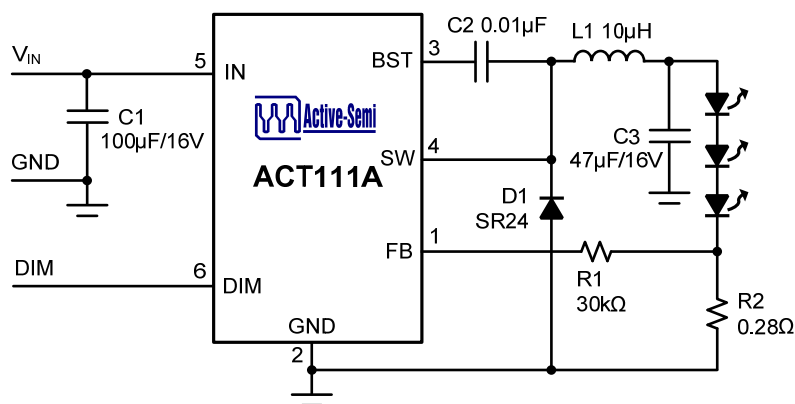

## ORDERING INFORMATION

PART NUMBER	TEMPERATURE RANGE	PACKAGE	PINS	PACKING	TOP MARK
ACT111AUS-T	-40°C to 85°C	SOT23-6	6	TAPE & REEL	FRWE

## PIN CONFIGURATION

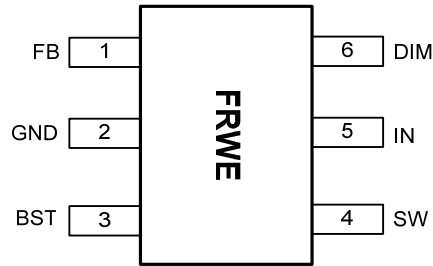

SOT23-6  
ACT111AUS-T

## PIN DESCRIPTIONS

PIN NUMBER	PIN NAME	PIN DESCRIPTION
1	FB	Feedback Input for regulating LED current. The voltage at this pin is regulated to 0.1V. An external resistor is connected from this pin to ground to sense the LED current.
2	GND	Ground.
3	BST	Bootstrap pin. This provides power to the internal high-side N channel MOSFET gate driver. Connect a 2.2nF capacitor from the pin to SW pin.
4	SW	Internal N channel power MOSFET source output pin. Connect it to one end of power inductor.
5	IN	Power supply input. Bypass this pin with a 10μF ceramic capacitor to GND, placed as close to the IC as possible.
6	DIM	PWM signal input for dimming control. Apply PWM signal with amplitude greater than 2V to this pin. The device is enabled as DIM pin open and disabled when it is connected to G.

## ABSOLUTE MAXIMUM RATINGS<sup>①</sup>

PARAMETER	VALUE	UNIT
IN to GND	-0.3 to 34	V
SW to GND	-1 to $V_{IN} + 1$	V
BST to GND	$V_{SW} - 0.3$ to $V_{SW} + 7$	V
FB to GND	-0.3 to + 6	V
DIM to GND	-0.3 to + 3	V
Continuous SW Current	Internally Limited	A
Junction to Ambient Thermal Resistance ( $\theta_{JA}$ )	220	°C/W
Maximum Power Dissipation	0.5	W
Operating Junction Temperature	-40 to 150	°C
Storage Temperature	-55 to 150	°C
Lead Temperature (Soldering, 10 sec)	300	°C

①: Do not exceed these limits to prevent damage to the device. Exposure to absolute maximum rating conditions for long periods may affect device reliability.

## ELECTRICAL CHARACTERISTICS

( $V_{IN} = 12V$ ,  $T_A = 25^\circ C$ , unless otherwise specified.)

PARAMETER	SYMBOL	TEST CONDITIONS	MIN	TYP	MAX	UNIT
Input Voltage	$V_{IN}$		4.8		30	V
$V_{IN}$ Turn-On Voltage		Input Voltage Rising	4.0	4.4	4.7	V
$V_{IN}$ UVLO Hysteresis				250		mV
Supply Operation Current		$V_{FB} = 0.2V$		1	2	mA
Switching Frequency			1.15	1.4	1.65	MHz
Maximum Duty Cycle		$V_{FB} = 0.08V$	90	92	95	%
Minimum On-Time				75		ns
Effective FB Voltage		$5V \leq V_{IN} \leq 20V$	97	102	107	mV
FB Leakage Current					100	nA
CC Current Limit		Duty Cycle = 5%	1.8	2.4	3.0	A
PWM DIM Frequency					10	kHz
DIM Threshold Voltage		DIM rising		1.66		V
DIM Hysteresis		DIM rising		100		mV
DIM Input Leakage					1	$\mu A$
High-Side Switch On-Resistance				0.3		$\Omega$
Low-Side Switch On-Resistance				15		$\Omega$
Thermal Shutdown Temperature				160		°C
Thermal Hysteresis				10		°C

## TYPICAL PERFORMANCE CHARACTERISTICS

( $T_A = 25^\circ\text{C}$ , unless otherwise specified.)

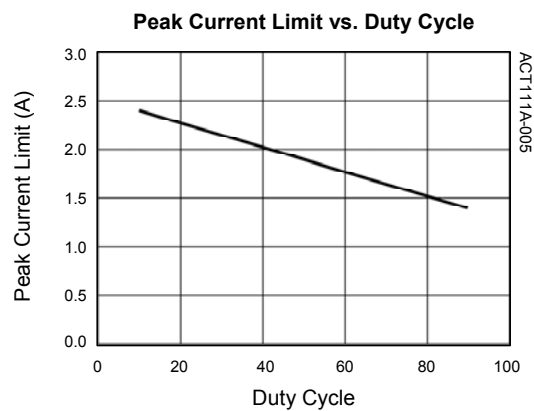
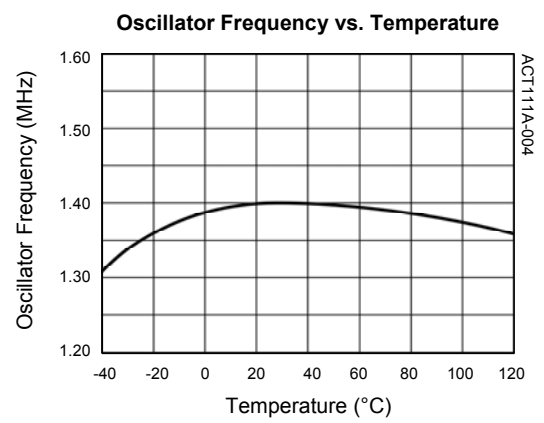
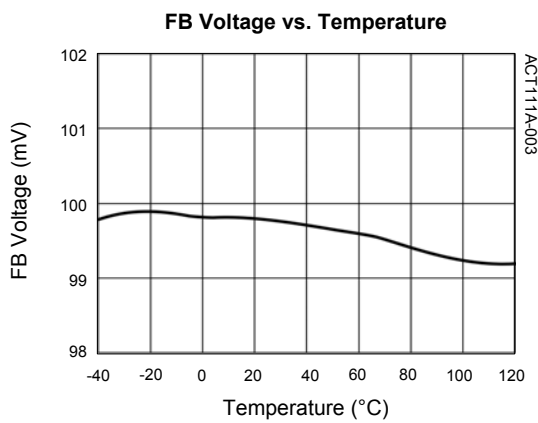
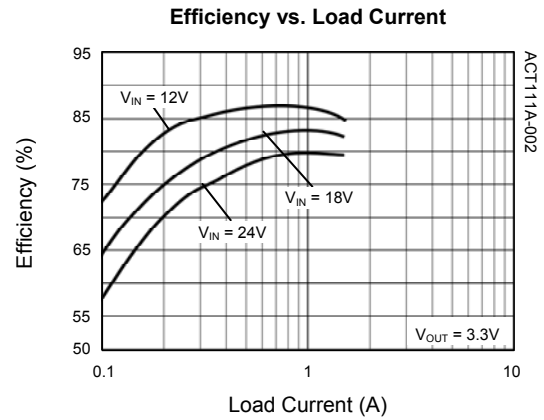
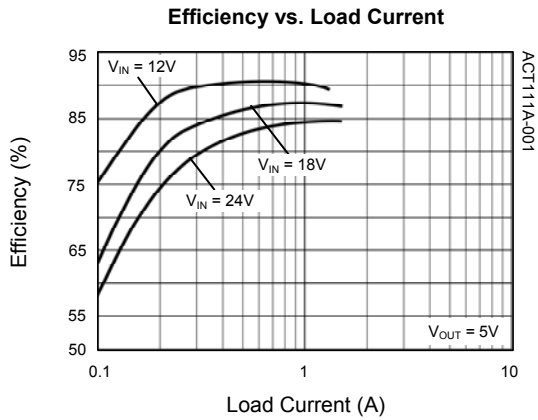

## FUNCTIONAL BLOCK DIAGRAM

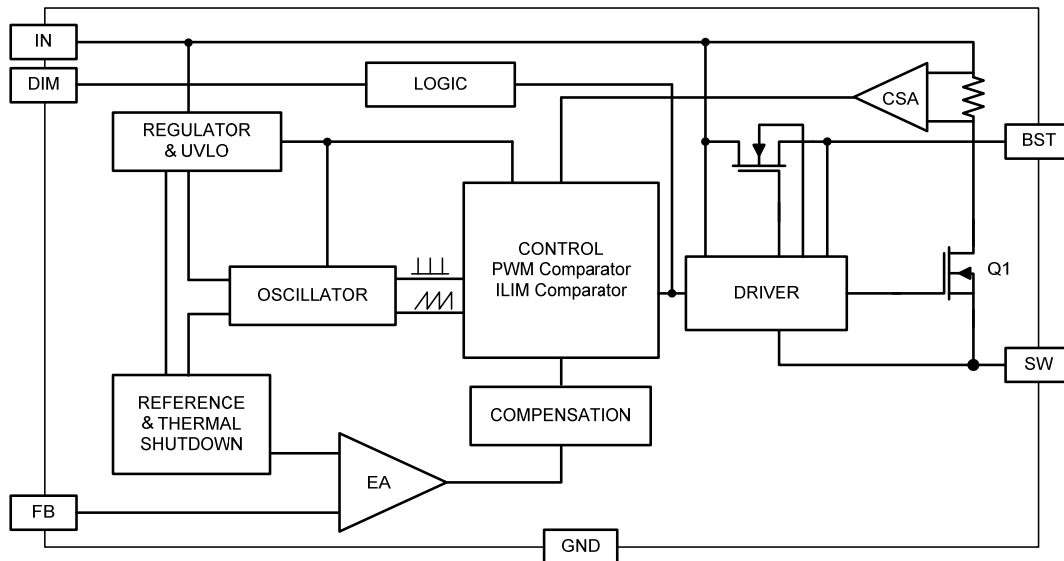

## FUNCTIONAL DESCRIPTION

The ACT111A is a current-mode step-down 1.5A LED driver with no extra external compensation components. It has wide 4.8V to 30V input voltage range for a variety of power sources. The 100mV low feedback voltage and an external current sense resistor makes it deliver LED current programmable from 20mA to 700mA with efficiency up to 96%. The device contains an internal, low-resistance, high-voltage power MOSFET, and operates at a high 1.4MHz operating frequency to ensure a compact, high-efficiency design with excellent AC and DC performance. It is in a space saving SOT23-6 package.

The ACT111A is a current mode regulator. It controls the inductor peak current by the feedback loop during each switching cycle. Therefore, it improves loop dynamics. In steady state operation, a pulse from the oscillator starts a cycle to turn on the internal top MOSFET switch. Current in the switch and the external inductor ramps up. As the current level reaches the voltage level defined by the internal error amplifier output, the internal switch is turned off. The current in the inductor flows through the external Schottky diode. The inductor current is continuously adjusted by the internal error amplifier. In the ACT111A, the voltage to the FB pin compares to the internal accurate 100mV reference voltage to generate error signal. Therefore, as a current sense resistor in series with LED is connected to the FB pin, the LED current is well regulated.

LED dimming can be performed by directly

connecting a PWM signal (frequency range from 0.1kHz to 10kHz) to the DIM pin. If the DIM pin is unconnected or pulled high, the ACT111A operates normally.

### Inductor Selection

The optimum inductor for a given application has to be chosen with operation condition. The inductor current waveform is a triangle with an average value equal to the load current in continuous conduction mode (CCM). The peak switch current is equal to the output current plus half the peak-to-peak inductor ripple current and is limited to around 1.8A to protect itself and power stage from overload condition. Therefore, the maximum output current to a load depends on the switch current limit, the inductor value, and the input and output voltages.

The peak-to-peak inductor ripple current is usually controlled to 20%-30% of the output current and the inductor value is selected accordingly by:

$$L = \frac{(1 - D)(V_O + V_F)}{\Delta I_L \times f} \quad (1)$$

where  $f$  is 1.4MHz switching frequency of the ACT111A,  $V_O$  is the output voltage,  $V_F$  is the Schottky diode forward voltage drop (~0.4V), and  $D$  is switching duty cycle given by:

$$D = \frac{V_O + V_F}{V_{IN} + V_F} \quad (2)$$

The inductor's RMS current rating must be greater than the maximum load current and its saturation current should be at least 30% higher. For high

efficiency and good thermal condition, the inductor DC resistance (DCR) should be less than 0.25Ω. The peak inductor and switch current is:

$$I_{L(PK)} = I_{SW(PK)} = I_O + \frac{\Delta I_L}{2} \quad (3)$$

The peak current must be less than the current limit to maintain output regulation.

## Input Capacitor Selection

A step-down regulator draws pulsing current from input source. The input capacitor is required to reduce the voltage ripple at the ACT111A input and force the pulsing current into a local loop to minimize EMI. The input capacitor must have low impedance at the switching frequency to effectively reduce the voltage ripple and EMI, and it must have an adequate RMS ripple current rating. The RMS current for the input capacitor is:

$$I_{CIN\_RMS} = I_O \times \frac{\sqrt{V_O(V_{IN} - V_O)}}{V_{IN}} < \frac{I_O}{2} \quad (4)$$

For best performance choose a ceramic type capacitor with X5R or X7R dielectrics due to their low ESR and small temperature coefficients. However, low ESR tantalum or electrolytic types may also be used, provided that the RMS ripple current rating is higher than 50% of the output current. For most applications, a 10μF capacitor is sufficient. The input capacitor should be placed close to the IN and G pins of the ACT111A, with shortest possible traces. In the case of tantalum or electrolytic types, connect a small parallel 0.1μF ceramic capacitor right next to the ACT111A.

## Output Capacitor Selection

A ceramic capacitor with X5R or X7R dielectric provides the best results over a wide range of applications. The output capacitor also needs to have low ESR to keep low output voltage ripple. The output ripple voltage is:

$$V_{O\_RIPPLE} = I_O \times K_{RIPPLE} \times ESR + \frac{I_O \times K_{RIPPLE}}{8 \times f \times C_O} \quad (5)$$

where  $I_O$  is the output current,  $K_{RIPPLE}$  is the ripple factor (typically 20% to 30%), ESR is the equivalent series resistor of the output capacitor,  $f$  is 1.4MHz switching frequency,  $L$  is the inductor value, and  $C_O$  is the output capacitance. In the case of ceramic output capacitors, ESR is very small and does not contribute to the ripple. In the case of tantalum or electrolytic type, the ripple is dominated by ESR multiplied by the ripple current. In this case, the output capacitor is chosen to have low ESR capacitor with ESR typically less than 50mΩ.

## Rectifier Diode Selection

Use a Schottky diode as the rectifier to conduct current when the ACT111A internal top MOSFET switch is off. In steady state operation, average forward current in the diode is:

$$I_{D\_AVG} = I_O \frac{V_{IN} - V_O}{V_{IN}} \quad (6)$$

The Schottky diode must have current rating higher than the maximum output current and the reverse voltage rating higher than the maximum input voltage.

## PWM and Analog Dimming

There are two dimming schemes to control LED average current during steady state operation. As those applications requiring a PWM logic signal to control dimming, the PWM signal could be directly applied to the DIM pin of the ACT111A as shown in Figure 1. The LEDs turn on with full load to completely turn off. The average LED current increase proportionally to the duty cycle of the PWM signal. The turn-on threshold voltage is 1.66V with 100mV hysteresis. The frequency of the PWM signal is from 100 Hz up to 10 kHz.

If analog dimming scheme is preferred in an application, a DC voltage to control the FB voltage, as shown in Figure 2 is used. As the DC voltage increases from 0 to certain level determined by the application like 5V, current starts to flow down  $R_{DIM}$ ,  $R_1$  and  $R_S$ . As the control loop maintains the feedback voltage  $V_{FB}$  to be 100mV, the current through the LEDs will linearly decrease to zero.

**Figure 1:**  
PWM Dimming

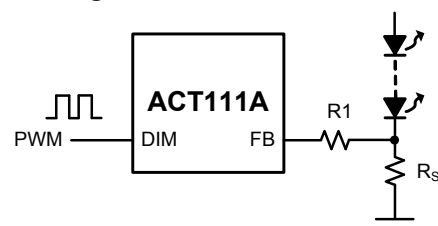

**Figure 2:**  
Analog Dimming

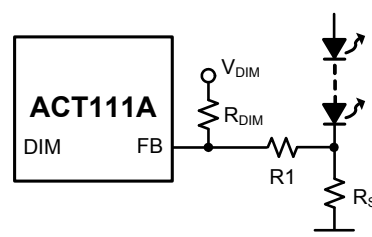

The following equation determines resistor values:

$$R_{DIM} = R1 \frac{V_{DIM(MAX)} - V_{FB}}{V_{FB}} \quad (7)$$

According to the equation, Table 1 shows the respective resistor values with different DC dimming voltage.  $V_{TB}$  is 100mV, R1 is chosen to be 30k $\Omega$ .

**Table 1:**

**Open LED Protection**

$V_{DIM(MAX)}$ (V)	R1 (k $\Omega$ )	$R_{DIM}$ (k $\Omega$ )
5	30	1470
3.3	30	976
2	30	576

In case of LED failure, the ACT111A will operate at maximum duty cycle due to the feedback voltage drops to zero. This will result in the output voltage moving up. To prevent over voltage on the output, a Zener and a series resistor are used as shown in Figure 3 and Figure 6 (ZD1 and R4).

**Thermal Shutdown**

The ACT111A automatically turns off when the IC junction temperature exceeds 160 $^{\circ}$ C, and reenables when the IC junction temperature drops by 10 $^{\circ}$ C (typ).

**PC Board Layout**

To achieve good performance, it is extremely important to have optimized component placement and layout on PCB for a high switching frequency and high efficiency regulator. Here are recommendations for the layout: Place input capacitor to IN pin, inductor and diode to SW pin as close as possible to reduce the voltage ringing at these pins. Place the current sense resistor close to FB pin. Minimize ground noise by connecting high current ground returns, the input capacitor ground lead, and the output filter ground lead to a single point (star ground configuration). There are two power loops in normal operation, one is formed when the SW is high and the high current flows through input capacitor, internal MOSFET, inductor, LEDs,  $R_{SENSE}$  to ground. The other loop is through inductor, LEDs,  $R_{SENSE}$ , ground to diode. Make these loop areas as small as possible to minimize noise interaction. SW pad is a noisy node switching from VIN to GND. It should be isolated away from the rest of circuit for good EMI and low noise operation.

TYPICAL APPLICATIONS

Figure 3:  
12VAC Input 3x0.35A LED Driver with PWM Dimming

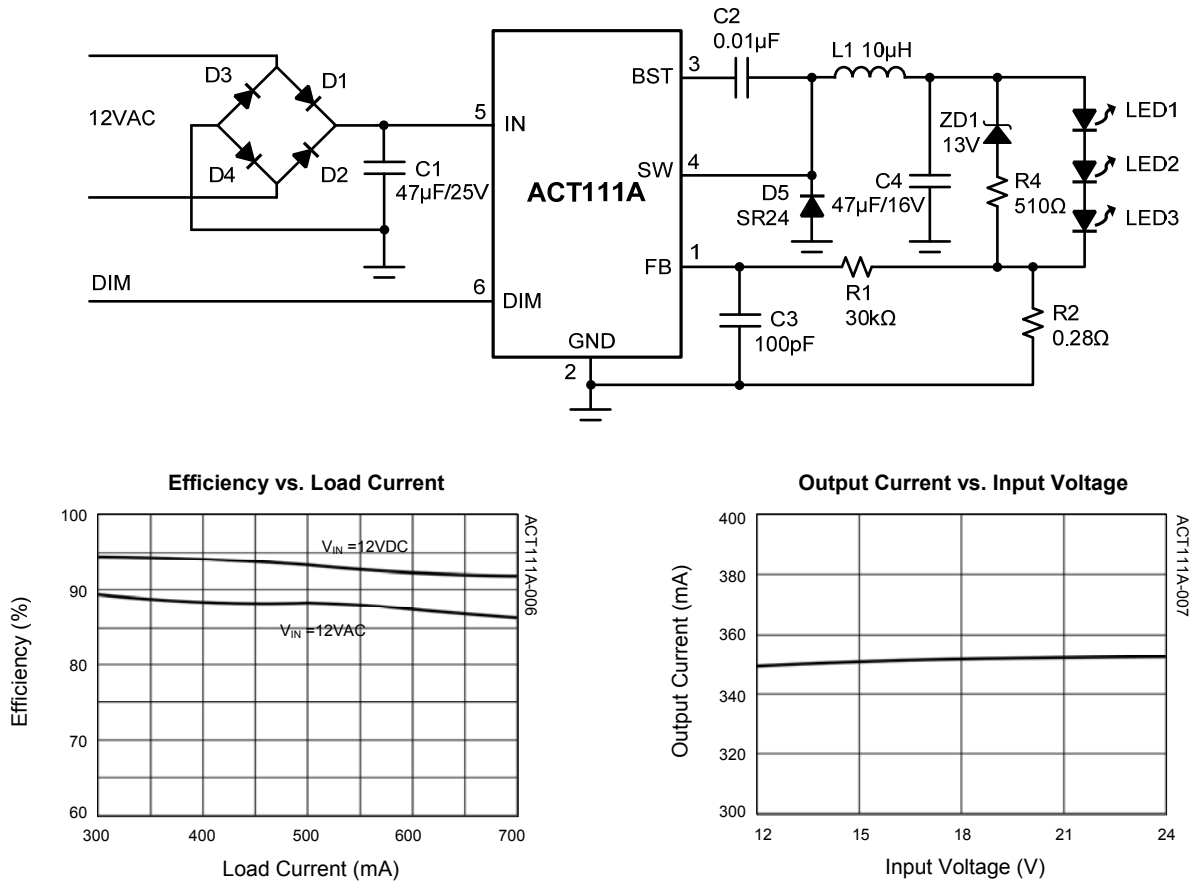

Figure 4:  
PCB Top Layer

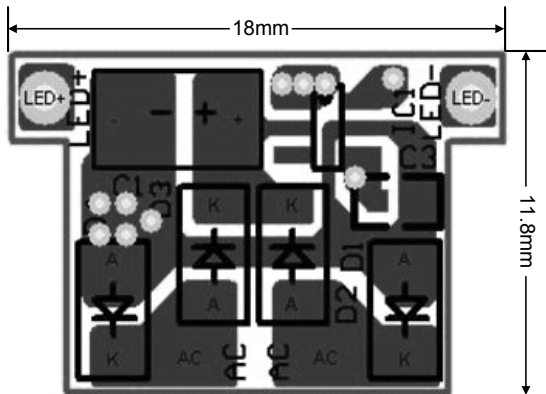

Figure 5:  
PCB Bottom Layer

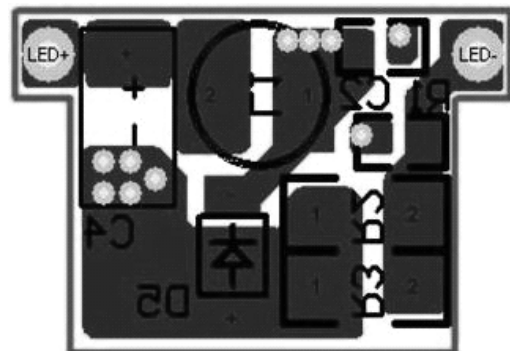



Table 2:

## Bill of Material

ITEM	REFERENCE	DESCRIPTION	MANUFACTURER
1	U1	IC, ACT111A	Active-Semi
2	C1	Capacitor Tantalum, 47 $\mu$ F/25V, E Case	AVX
3	C2	Capacitor, Ceramic, 0.01 $\mu$ F/50V, 0603	POE
4	C3	Capacitor, Ceramic, 100pF/25V, 0603	POE
5	C4	Capacitor Tantalum, 47 $\mu$ F/16V, D Case	AVX
6	D1 - D4	Diode Schottky, 40V/1A, SS14, SMA	PANJIT
7	D5	Schottky Barrier Rectifier, SR24, 40V/2.0A, SMB	PANJIT
8	ZD1	Diode Zener, GLZ13A, 13V, 0.5W, MINI-MELF	PANJIT
9	R1	Meter Film Resistor, 30k $\Omega$ , 0603, 5%	TY-OHM
10	R2	Meter Film Resistor, 0.28 $\Omega$ , 1206, 1%	TY-OHM
11	R4	Meter Film Resistor, 510 $\Omega$ , 1206, 5%	TY-OHM
12	L1	SMD Power Inductor, SR0604100ML, 10 $\mu$ H, $\pm$ 20%	QianRu

Figure 6:  
24VDC Input 5x0.7A LED Driver with PWM Dimming

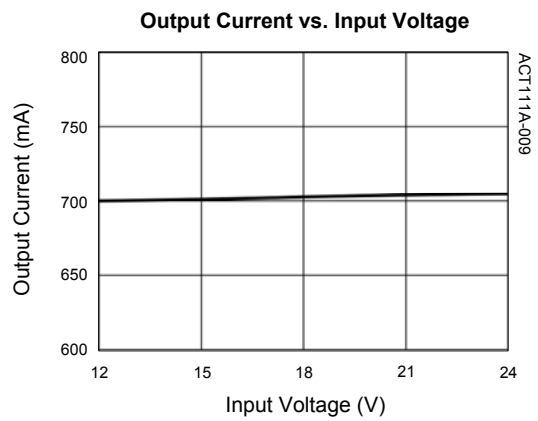
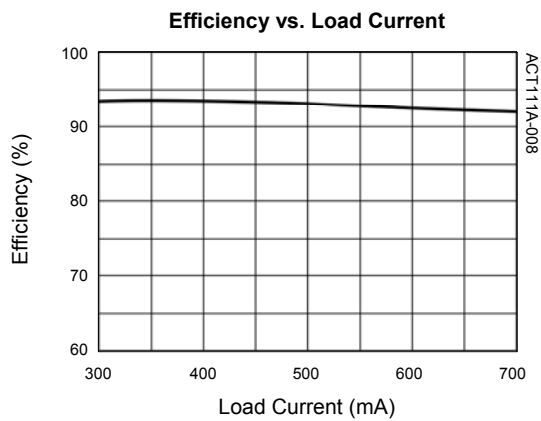
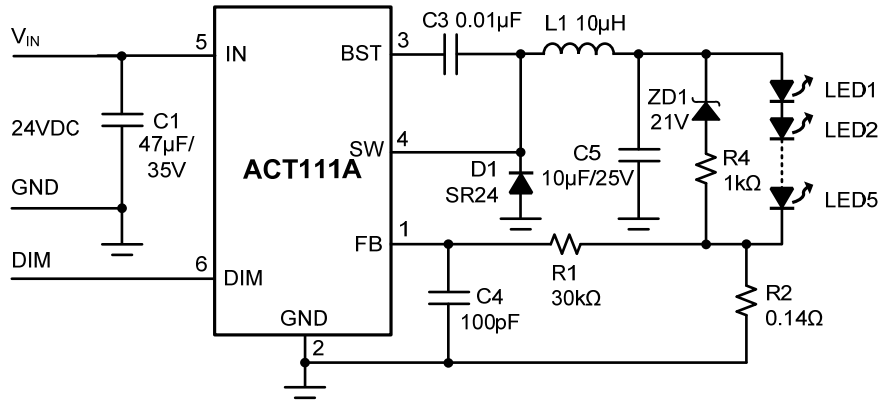

Figure 7:  
PCB Top Layer

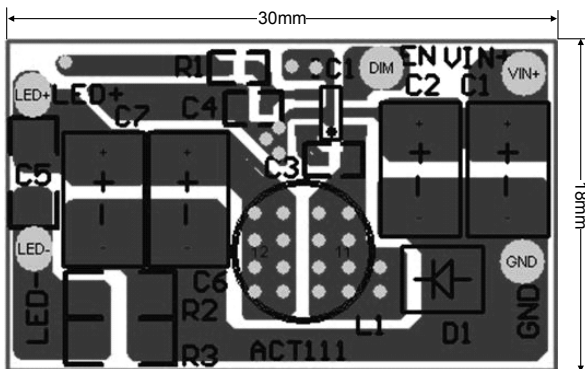
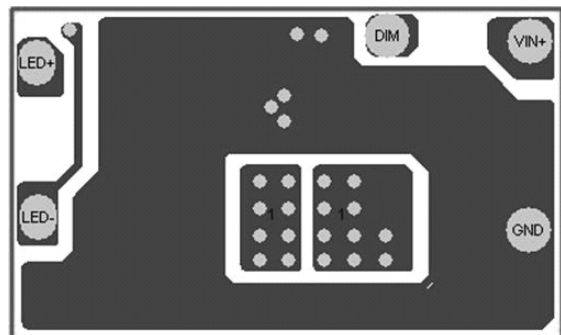

Figure 8:  
PCB Bottom Layer



**Table 3:**  
**Bill of Material**

ITEM	REFERENCE	DESCRIPTION	MANUFACTURER
1	U1	IC, ACT111A	Active-Semi
2	C1	Capacitor Tantalum, 47 $\mu$ F/35V, E Case	AVX
3	C3	Capacitor, Ceramic, 0.01 $\mu$ F/50V, 0603	POE
4	C4	Capacitor, Ceramic, 100pF/25V, 0603	POE
5	C5	Capacitor Tantalum, 10 $\mu$ F/25V, D Case	AVX
6	D1	Schottky Barrier Rectifier, SR24, 40V/2.0A, SMB	PANJIT
7	ZD1	Diode Zener, GLZ21A, 21V, 0.5W, MINI-MELF	PANJIT
8	R1	Meter Film Resistor, 30k $\Omega$ , 0603, 5%	TY-OHM
9	R2	Meter Film Resistor, 0.14 $\Omega$ , 1206, 1%	TY-OHM
10	R4	Meter Film Resistor, 1k $\Omega$ , 1206, 5%	TY-OHM
11	L1	SMD Power Inductor, SR0604100ML, 10 $\mu$ H, $\pm$ 20%	QianRu

## PACKAGE OUTLINE

### SOT23-6 PACKAGE OUTLINE AND DIMENSIONS



SYMBOL	DIMENSION IN MILLIMETERS		DIMENSION IN INCHES	
	MIN	MAX	MIN	MAX
A	-	1.450	-	0.057
A1	0.000	0.150	0.000	0.006
A2	0.900	1.300	0.035	0.051
b	0.300	0.500	0.012	0.020
c	0.080	0.220	0.003	0.009
D	2.900 BSC		0.114 BSC	
E	1.600 BSC		0.063 BSC	
E1	2.800 BSC		0.110 BSC	
e	0.950 BSC		0.037 BSC	
e1	1.900 BSC		0.075 BSC	
L	0.300	0.600	0.012	0.024
θ	0°	8°	0°	8°

Active-Semi, Inc. reserves the right to modify the circuitry or specifications without notice. Users should evaluate each product to make sure that it is suitable for their applications. Active-Semi products are not intended or authorized for use as critical components in life-support devices or systems. Active-Semi, Inc. does not assume any liability arising out of the use of any product or circuit described in this datasheet, nor does it convey any patent license.

Active-Semi and its logo are trademarks of Active-Semi, Inc. For more information on this and other products, contact [sales@active-semi.com](mailto:sales@active-semi.com) or visit <http://www.active-semi.com>.

 is a registered trademark of Active-Semi.